



**WACKER
NEUSON**
all it takes!

RD18

Tandem Rollers



Compact, maneuverable and powerful: the RD18 models

Thanks to their large drum diameter combined with a low machine center of gravity, the articulated RD18 models provide for first-class compaction performances. The end user benefits from maximum driving comfort here thanks to the three-point articulated joint and the intuitive operation. One special feature is the unilateral drum lifting point, which makes it possible to compact right up to the edge or on the wall.

- Optionally available as a tandem-axle roller or a combination roller
- Compaction in road and highway construction up to the edge due to the unilateral drum lifting point
- Installed articulated pendulum joint ensures for even compaction, a high level of maneuverability and a high level of driving stability
- Optimal visual conditions due to the slim design

Unilateral drum lifting point

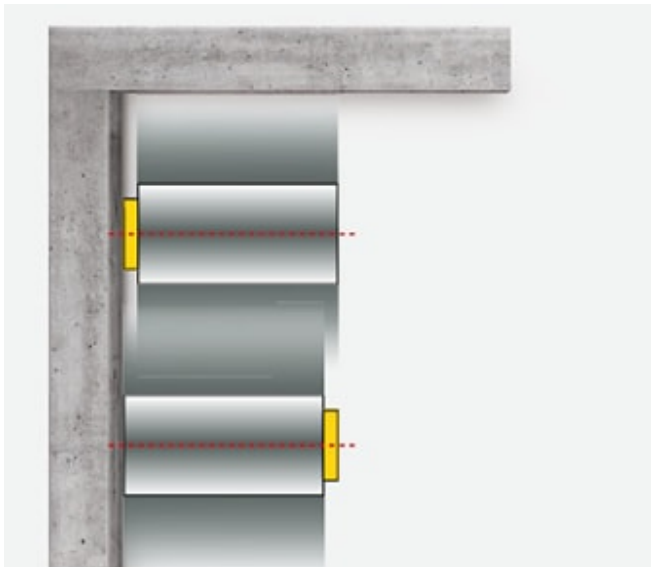

Excellent compaction performance right up to the edge:

With the unilateral lifting point of the drum, you have clear sided curb clearance that allows flush rolling on both sides and can move the roller directly up to walls or curbs. The re-compaction, e.g. with a rammer, is omitted.

Articulated pendulum joint

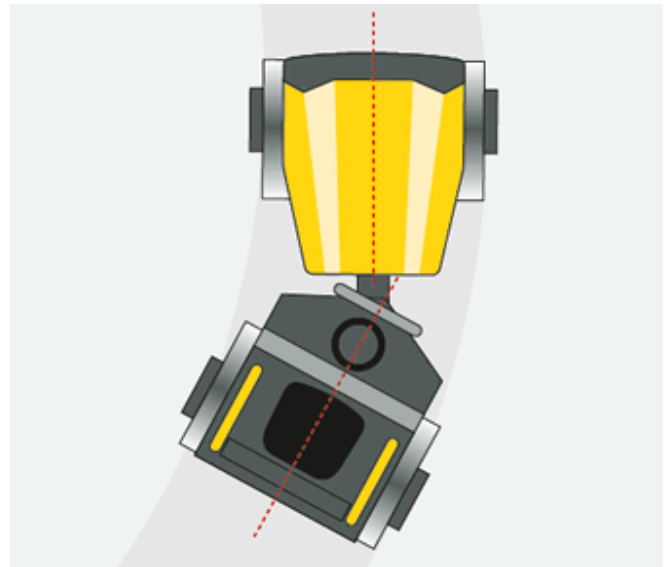

Uniform compaction, optimal driving stability: The three-point articulated pendulum joint ensures a uniform weight distribution on the front and rear drum at all times. This also improves the maneuverability and provides for maximum tipping safety and stability when turning curves.



hire



sales



parts



service

conplant.com.au | 1300 166 166



**WACKER
NEUSON**
all it takes!

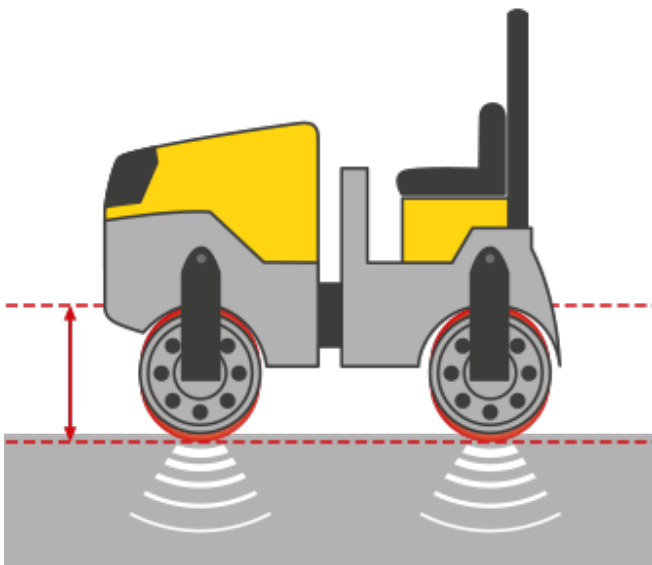

Tandem-axle roller

Front and rear with vibration drums.

The vibration drum optimally brings the material to be compacted into oscillation with quick successive vertical forces. The built-in eccentric weight provides for a fast rotation and you get an excellent compaction performance.

Suitable for:

All traditional compaction work

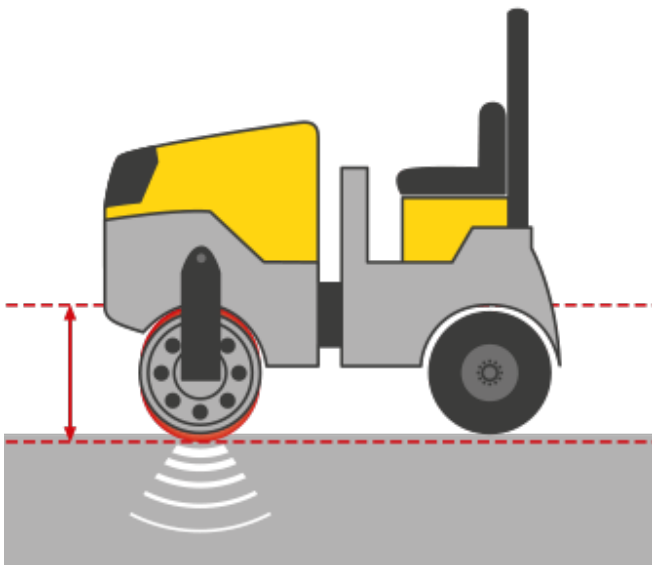

Combination roller

Vibration drum in the front, tires in the rear.

Even with the combination rollers, the forces are directed vertically downwards. The advantage over tandem-axle rollers are the tires. That is why combination rollers always have very good traction on gradients.

Suitable for:

Compaction work on gradients and in uneven ground conditions



hire



sales



parts



service

conplant.com.au | 1300 166 166



**WACKER
NEUSON**
all it takes!

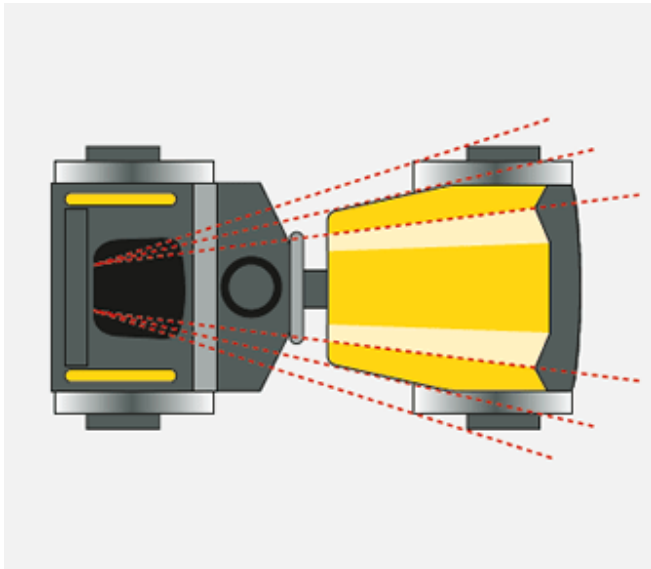

Optimal view

Everything is perfectly within view: With the specially designed, tapered design of the roller, you always have an excellent view of the drum edges, the machine environment and the job site.



Working area in view

The tapered design of the rollers gives you a good view of the drum edges or the machine environment.



Finely tiered selection of models

Tandem-axle rollers with vibration or oscillation drums as well as combination rollers in various weight classes: At Wacker Neuson, you will find exactly the model that you need for your project.



Excellent compaction

performance

Regardless of which of our rollers you choose – you will be excited about the compaction performance.



Excellent driving stability

Whether on rough terrain or when turning a curve – with the three-point articulated pendulum joint, you are always safely on the move.



hire



sales



parts



service

conplant.com.au | 1300 166 166



**WACKER
NEUSON**
all it takes!



iF Design Award 2016

The tandem roller series RD won the iF Design Award 2016 in the product category. The RD series convinced above all by the clearly structured operating elements and the intuitive handling, which is supported by the design.



hire



sales



parts



service

conplant.com.au | 1300 166 166



**WACKER
NEUSON**
all it takes!

RD18 Technical specifications

	RD18-80	RD18-100	RD18-100C
Operating data			
Operating weight with roll-over protective structure kg	1,580	1,670	1,630
Operating weight max. kg	1,840	1,950	1,830
L x W x H mm	2,260 x 856 x 2,210	2,260 x 1,056 x 2,210	2,260 x 1,040 x 2,210
Drum width mm	800	1,000	1,000
Drum diameter mm	620	620	620
Operating width mm	856	1,056	1,000
Ground clearance middle mm	230	230	240
Drum type front	smooth/undivided	smooth/undivided	smooth/undivided
Drum type rear	smooth/undivided	smooth/undivided	Tires
Axle load front kg	765	815	805
Axle load rear kg	815	855	825
Centrifugal force level I kN	25	25	25
Centrifugal force level II kN	16	16	16
Frequency level I Hz	65	65	65
Frequency level II Hz	52	52	52
Amplitude mm	0.5	0.45	0.45
Linear force - front / rear static N/mm	9.6 / 10.2	8.1 / 8.6	7.9 / 0
Advance travel max. m/min	183	183	183
Gradeability with vibration %	30	30	30
Gradeability without vibration %	40	40	40
Turning radius inside mm	2,230	2,130	2,130
Engine / Motor			
Engine / Motor type	3-cylinder diesel engine	3-cylinder diesel engine	3-cylinder diesel engine
Engine / Motor manufacturer	Kubota	Kubota	Kubota
Engine performance ISO 14396 kW	14.8	14.8	14.8
Filling capacities			
Tank capacity fuel l	33	33	33
Tank capacity water l	70	70	70



hire



sales



parts



service

conplant.com.au | 1300 166 166



**WACKER
NEUSON**
all it takes!

Please note

that product availability can vary from country to country. It is possible that information / products may not be available in your country. More detailed information on engine power can be found in the operator's manual; the stated power may vary due to specific operating conditions.

Subject to alterations and errors excepted. Applicable also to illustrations.

Copyright © 2019 Wacker Neuson SE.



hire



sales



parts



service

conplant.com.au | 1300 166 166